

# ES1530LC

## LIGHTWEIGHT ELECTRIC SCISSOR LIFT

SCISSOR LIFT



## STANDARD SPECIFICATIONS

Performance	Indoor	Outdoor
Platform Height (Elevated)	15-ft / 4.5-m	10-ft / 3-m
Platform Capacity	500-lb / 227-kg	500-lb / 227-kg
Capacity on Platform Extension	250-lb / 115-kg	250-lb / 115-kg
Number of Occupants	1	1
Lift / Lower Time	19/19 seconds	19/19 seconds
Maximum Drive Height	33.1-in / 0.84-m	33.1-in / 0.84-m
Weight*	1,940-lb / 880-kg	1,940-lb / 880-kg
Max. Ground Bearing Pressure	6.8 psi / 0.5 kg/cm <sup>2</sup>	6.8 psi / 0.5 kg/cm <sup>2</sup>
Drive Speed (Lowered)	1.86 mph / 3 km/h	1.86 mph / 3 km/h
Drive Speed (Raised)	-	-
Gradeability	35%	35%
Max Tilt Rating (Side-to-Side)	2.0 Degrees	2.0 Degrees
Max Tilt Rating (Fore and Aft)	3.0 Degrees	3.0 Degrees

\*Certain options or country standards increase weight

### KEY SPECS

#### Platform Height

Indoor: 15-ft / 4.5-m  
Outdoor: 10-ft / 3.0-m

#### Platform Capacity

500-lb / 227-kg

#### Number of Occupants

1

#### Stowed Drive Speed

1.86 mph / 3.0 km/h

### KEY FEATURES

- Lightweight and Robust. Suitable for both indoor and outdoor use. Applicable for maintenance and construction fit-out applications.
- Compact and capable of turning on the spot. Ideal for use in space-constrained areas.
- Superb drive capabilities with 35% gradeability and 3.0 km/h speed. Excellent for getting around the most challenging jobsites.
- Designed to JLG's principle of making products that deliver the best value to owners, in terms of lower maintenance cost, high productivity, and durability and longevity.
- Complies with A92.20 ANSI, GB, MOL70 regulations, achieving the highest standards.

### Power

Batteries	2 x 12V 105 amp-hr
Charger	27 Amp (Universal Algorithm)
Drive	24V Electric

### Track

Standard	150 mm width, 40 Links
----------	------------------------

### Brakes

Electric, Friction

### Hydraulic System

Capacity	1.32 gal / 5 L
----------	----------------

## STANDARD FEATURES

- 22-in (55-cm) Foot-Actuated Deck Extension
- AC Receptacle in Platform
- All Motion Alarm
- Analyzer Port for Diagnostics
- Battery Condition Indicator
- 27 amp MultiFunction Universal Charger
- Diamond Tread Steel Deck
- Dynamic Braking
- Fork Lift Pockets
- Greaseless Kingpin Joints
- Horn
- Hourmeter
- Lanyard Attach Points
- Lifting and Tie Down Points
- Load Sensing System
- Lubrication Free Scissor Arm Bushings
- Manual Descent Cable
- Movable, Removable Platform Control
- Nickel Plated Pins
- Proportional Controls
- Removable Ladder
- Scissor Maintenance Prop
- Self Closing Gate
- Steel Swing-Out Doors
- Tilt Alarm and Light
- Visual Variable Tilt Indicator

## ACCESSORIES & OPTIONS

- Coiled Platform Control Box Cable
- Multi-Display Indicator MDI (Ground)
- Flashing Amber Beacon - LED
- Dual Flashing Amber Beacons - LED
- ANTI-VANDALISM PACKAGE

# ES1530LC

LIGHTWEIGHT ELECTRIC SCISSOR LIFT

SCISSOR LIFT



## DIMENSIONS

All dimensions are approximate

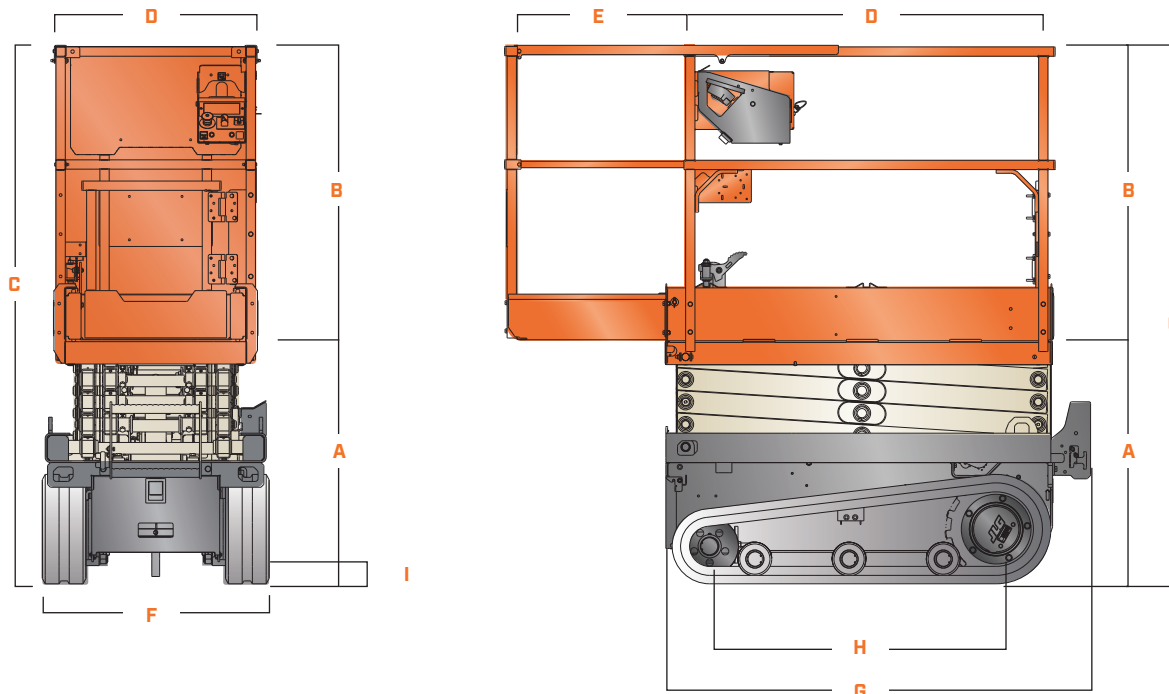

<b>A.</b> Platform Height (Lowered)	0.84-m	<b>F.</b> Machine Width	78-cm
<b>B.</b> Platform Railing Height	1.1-m	<b>G.</b> Machine Length	1.43-m
<b>C.</b> Machine Height	1.95-m	<b>H.</b> Wheelbase	0.985-m
<b>D.</b> Platform Width	0.62-m x 1.25-m	<b>I.</b> Ground Clearance	11-cm
<b>E.</b> Platform Extension	55-cm		



We provide coverage for one (1) full year, and cover all specified major structural components for five (5) years. Due to continuous product improvements, we reserve the right to make specification and/or equipment changes without prior notification. This machine meets or exceeds applicable ANSI and CSA requirements based on machine configuration as originally manufactured for intended applications. Please reference the serial number plate on the machine for additional information.



**JLG INDUSTRIES, INC.**  
Toll-free US 877-JLG-LIFT  
[JLG.com](http://JLG.com)

An Oshkosh Corporation Company