

# Model E450AJ

articulating BOOM LIFTS

## Performance

• Working Height	15.72 m
• Working Outreach	7.89 m
• Up and Over Height	7.70 m
• Swing (non-continuous)	360°
• Platform Capacity – Unrestricted	230 kg
• Platform Rotator (Hydraulic)	180°
• Jib – Overall Length	1.24 m
• Jib – Range of articulation	144° (+84°/-60°)
A. Platform Size	0.76 m x 1.52 m
B. Overall Width	1.75 m
C. Tailswing (working condition)	Zero
D. Stowed Height	2.01 m
E. Stowed Length	6.45 m
F. Wheelbase	2.01 m
G. Ground Clearance	0.20 m
• Machine weight <sup>1</sup>	6,670 kg
• Maximum Ground Bearing Pressure	5.3 kg/cm <sup>2</sup>
• Drive Speed	5.2 km/h
• Gradeability	30%
• Turning Radius – Inside	0.61 m
• Turning Radius – Outside	3.15 m

<sup>1</sup> Certain options or country standards may increase weight and/or dimensions.



## Reach Diagram

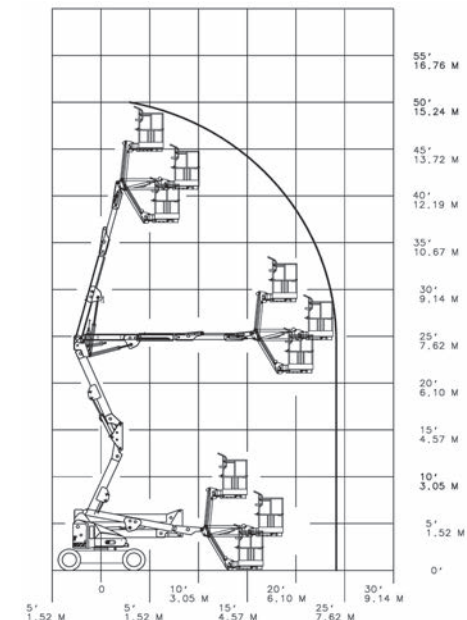

## Dimensions

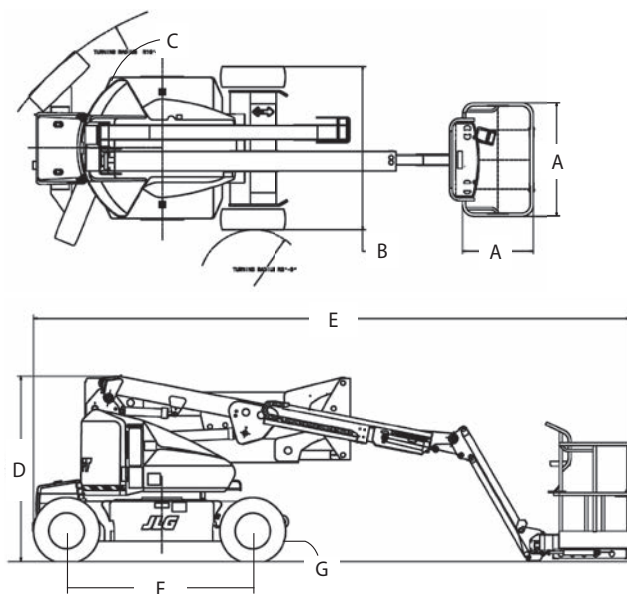

## IMPORTANT

JLG is continually researching and developing products and reserves the right to make modifications without prior notice. All data in this document is indicative. Certain options or country standards will increase weight. Specifications may change to meet country standards or with the addition of optional equipment.

Due to continuous product improvements, JLG Industries reserves the right to make specification and/or equipment changes without prior notification.

# JLG®

**JLG EMEA BV**

Polaris Avenue 63  
2132 JH Hoofddorp  
The Netherlands  
Tel: +31 (0)23 565 5665  
Fax: +31 (0)23 557 3750  
[www.jlg.com](http://www.jlg.com)

**An Oshkosh Corporation Company**